



Micon Automation Systems Pvt. Ltd.



Temperature And Humidity Transmitter

KEHAO

THT101 Temperature and Humidity Transmitter

Application

KH101 is digital temperature and humidity sensor, widely used for air temperature and humidity monitoring in Medicines, food, meteorological environment, libraries, warehouse or storehouse, equipment room etc and also for industrial automation process monitoring and researching area.

Feature

High Safety	Safe guider built-in to ensure system safety
Digitized sensor	Adopts original imported digital type temperature and humidity sensor (IC) , high measuring accuracy and high stability
Output	4-20mA , 3 wire
Optional installation	Wall or duct type ,optional

Specification

Response time	3 second	Display Resolution	T: 0.01, H: 0.1
Temperature accuracy	$\pm 0.5^{\circ}\text{C}@25^{\circ}\text{C}$	Humidity accuracy	$\pm 3\% \text{RH}$
Measured range	T: -20 to 80°C or -20 to 120°C	Measured range	H: 0-100%
Storage temperature	-40 to 85 °C	Storage humidity	5-90% (No dew)
Power supply	24VDC	Power consumption	$\leq 0.5\text{W}$

Order Code

Item	KH101		Temperature and humidity transmitter with 4-20mA output
Installation Type	-B		Wall Type
	-G		
Temperature Range	-A		-20 to 80°C
	-B		-20 to 120°C

Diagram & Size

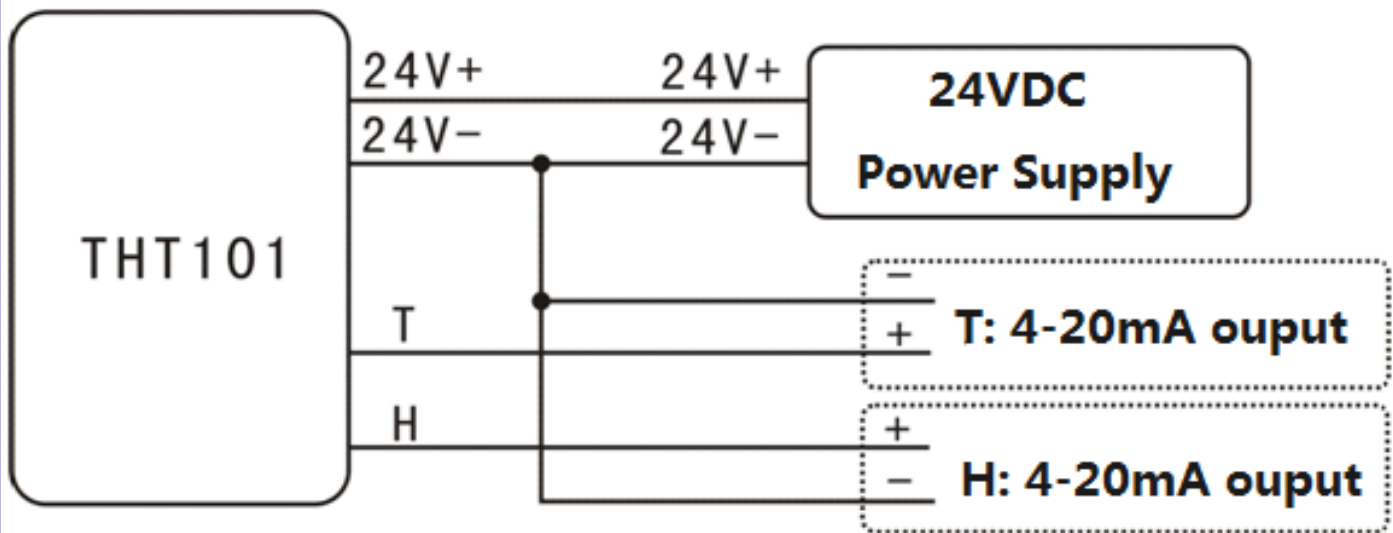

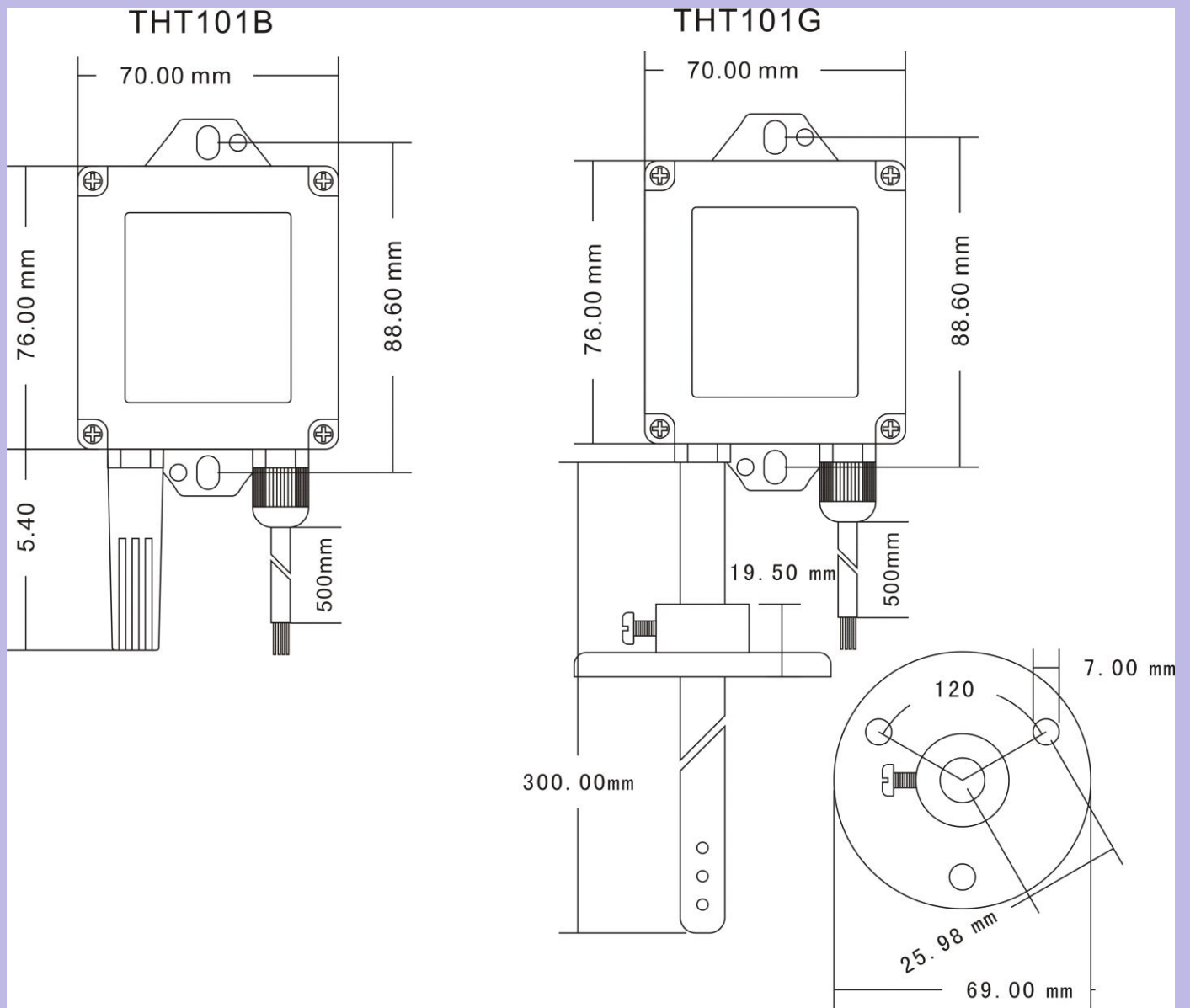

Micon Automation Systems Pvt. Ltd.

Address: A-814, Siddhi Vinayak Tower, B/H. Adani CNG Pump, Off S.G. Road, Makarba, Ahmedabad – 380 051

Tel: +91-079-29701447

Mo: +91-9723462390

Email: sales@miconindia.com, info@miconindia.com

Website: www.miconindia.com

Caution on Safety

Read instruction manual before using the product

Information in the catalog is subject to change without notice